

For air recirculation.  
Can be combined with flat kitchen hood series 200 / canopy extractor series 200.  
Odour reduction comparable to air extraction mode.  
Noise reduction of up to 3 dB when compared to conventional air recirculation filter systems.  
Extended change interval for the activated charcoal filter.  
For assembly in the upper cabinet.  
Consisting of filter housing with design panel, activated charcoal filter, flexible hose and 2 hose clamps.

**Color Variants**

AA211812

**Characteristics**

**Dimensions**

**Dimensions of the packed product (HxWxD)**

270x300x700

**Dimensions of the master case (mm)**

**Pallet dimensions**

100.0 x 80.0 x 120.0

**Quantity per packing unit**

**Standard number of units per pallet**

24

**Units per layer**

**Net weight**

4.5

**Gross weight**

6.1

**EAN code**

4242006267292

**Maximum Power**

**Voltage**

**Frequency**

**Length electrical supply cord**

**Plug type**

**Consumption and connection features**

2025-12-18

Page 1

View of upper cabinet from above with AA 211 812

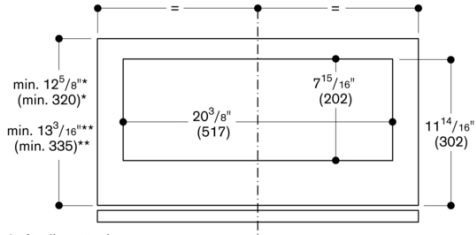

\* Appliance only  
\*\* Appliance with AA 210 490/460 lowering frame

Cross-section of upper cabinet with AA 211 812

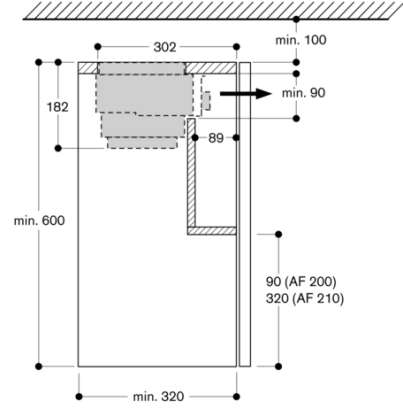

Cross-section of upper cabinet with AC 200 and AA 211 812

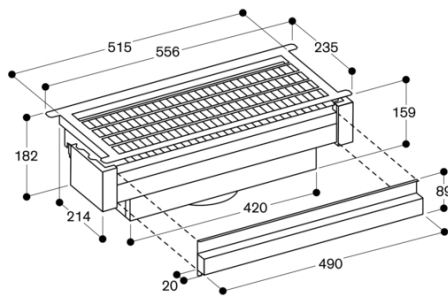
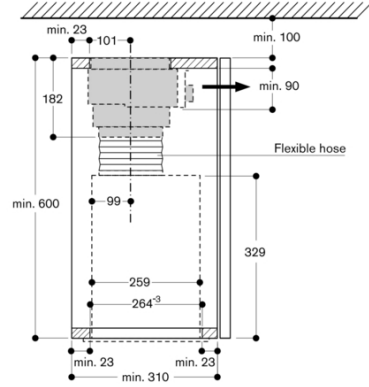

Removable filter panel

Cross-section of upper cabinet with AA 211 812 and AA 210 490/460 lowering frame

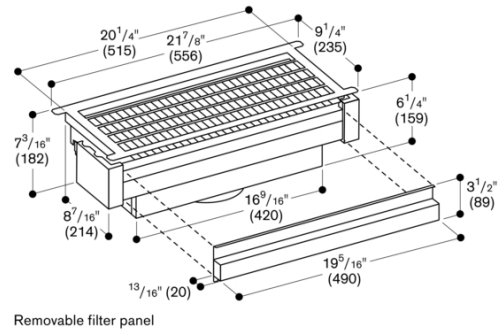
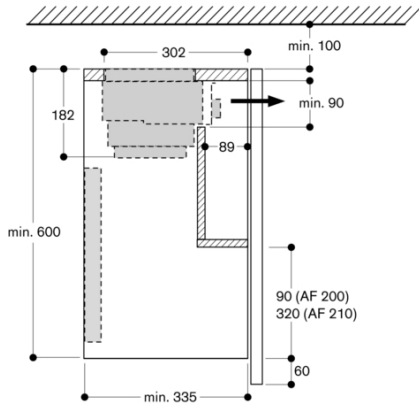

Removable filter panel

Cross-section of upper cabinet with AA 211 812

